

Installation

dot-spot GmbH & Co. KG
Industriestraße 1 A 90592 Schwarzenbruck
Tel: +49 (0) 9128/ 722217-0 Fax: +49 (0) 9128/ 722217-9
Mail: service@dot-spot.de Web: dot-spot.de

■ Produkt Parameter

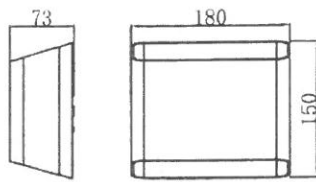

1. Model: Ljoma 15
2. Versorgungsspannung: AC 90-260 V
3. Leistung: LED 15 W
4. Schutzart: IP 54
5. Schutzklasse: 1
6. Operative Temperatur: -30° bis +45°

■ Komponenten

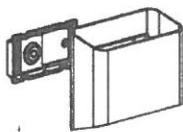

Basis Gehäuse

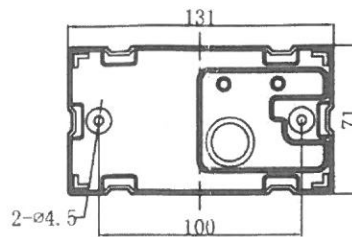

■ Installationsstufen

A

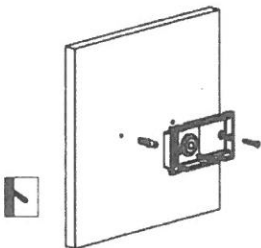

zur Installation Strom abschalten

B

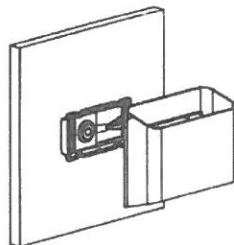

Anschluss von L, N und Schutzleiter

C

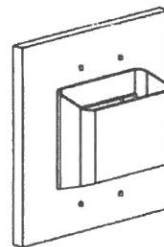

Fixieren des Gehäuses mit den Schrauben

D

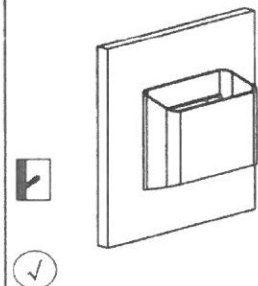

E

F

G

H

■ wichtige Hinweise

1. Die Leuchte sollte nur von autorisiertem Fachpersonal installiert werden.
2. Prüfen Sie, dass bei Installation der Strom abgeschaltet ist.
3. Lesen Sie die Anleitung sorgfältig durch.

Mounting Instruction

dot-spot GmbH & Co. KG
 Industriestraße 1 A 90592 Schwarzenbruck
 Tel: +49 (0) 9128/ 722217-0 Fax: +49 (0) 9128/ 722217-9
 Mail: service@dot-spot.de Web: dot-spot.de

Product Parameters

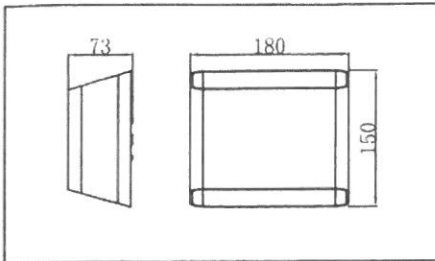

1. Model: Ljoma 15
2. Rated Voltage: AC 90-260V
3. Rated Power: LED 15W
4. IP Grade: IP65
5. Insulation protection level: Class I
6. Operating Temperature: -30~+45°C

Components and Tools

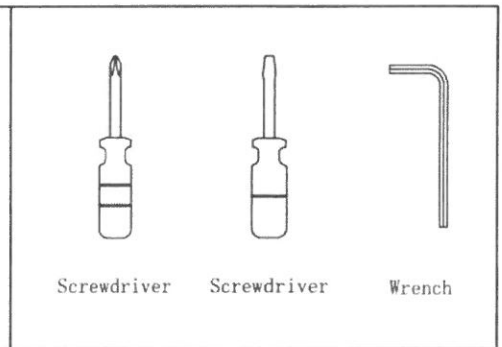
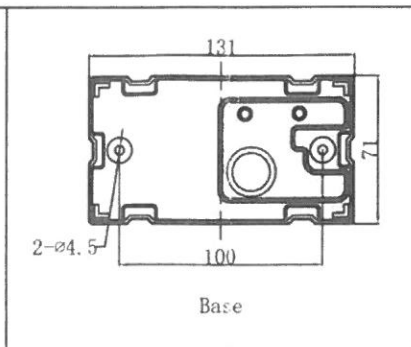
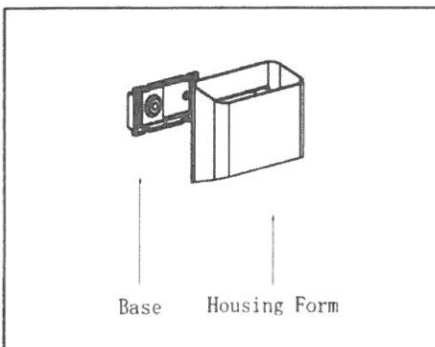

Installation Steps

A

OFF

▲ Please be sure to fasten tightly of the base.

B

▲ Live line for L terminal, Null line for N terminal, Ground line for E terminal.

C

▲ Make sure the screws be fixed tightly.

D

ON

▲ Connect the power supply, and light up the lamp.

E

F

G

H

Attention

1. Lamp should be installed by professional electrician;
2. Check the power switch has been turned off;
3. Please read this user guide carefully before installation and keep for future reference.